

**"FLEXORBER LP" by PULSEGUARD**  Since 1979

Typical "Sog" Series Pulsation Damper, with options.  
316L wetted metal plus PTFE Membrane.

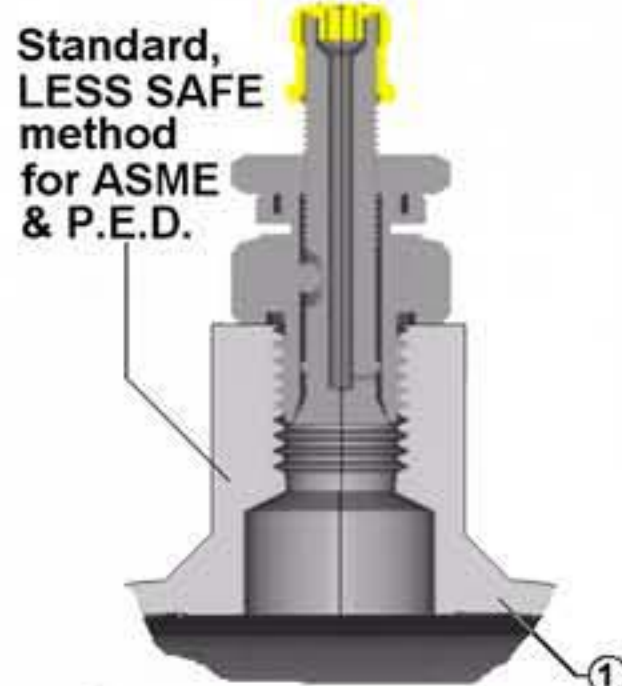
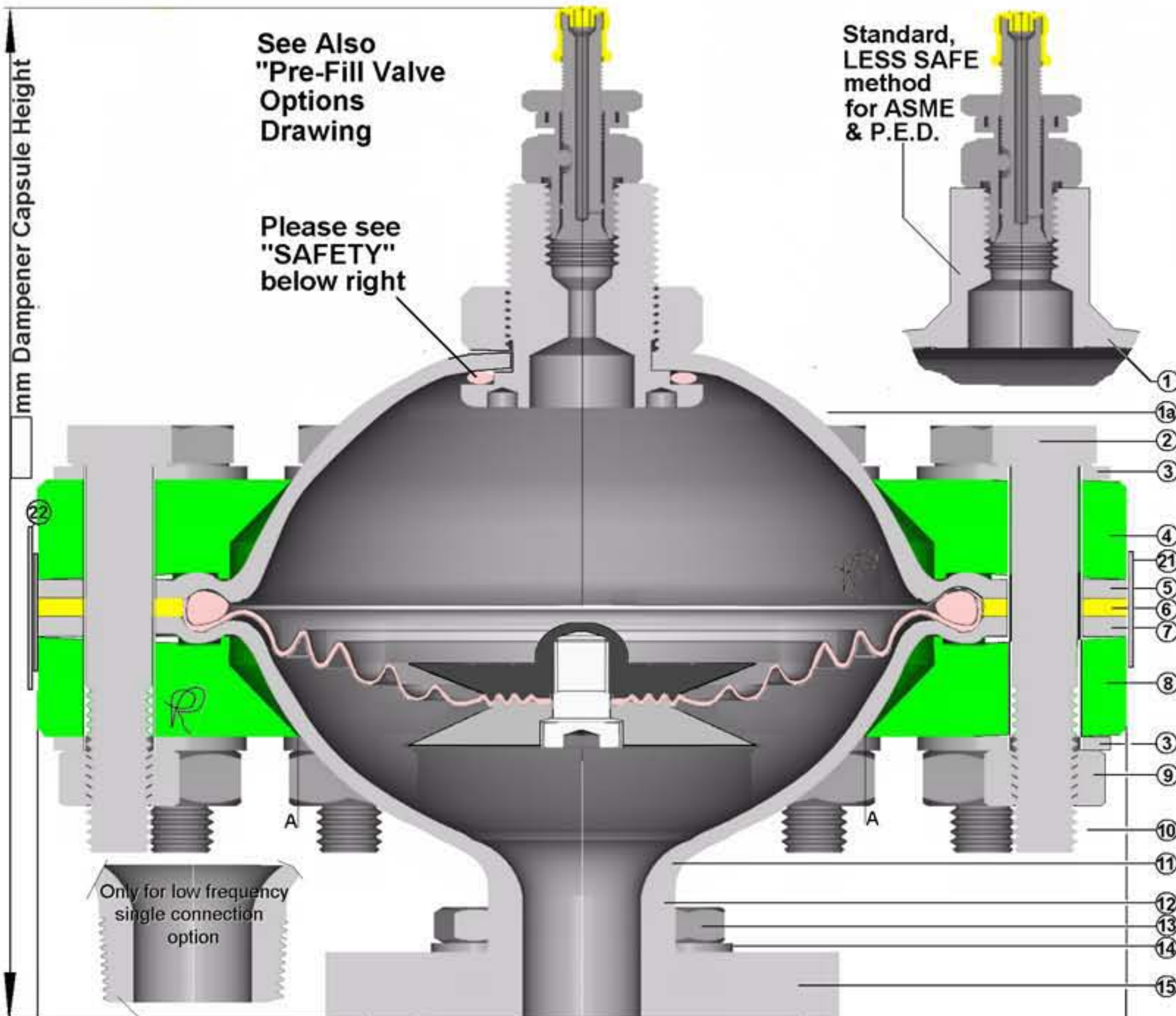

**DECLARATION** as required by PED Mandatory Essential Safety Requirement "ESR" state under design 2 at 2.1 the use of: "SAFETY COEFFICIENTS" this can not be complied with because neither EN 5500 nor EN 13445 have any Safety Coefficients.

Accordingly: It must be a fraud for any notified body to issue a certificate of conformity to ISO9001-2000 holders claiming any suitability for purpose from their quality system.

M. Packer, designer and "responsible party".

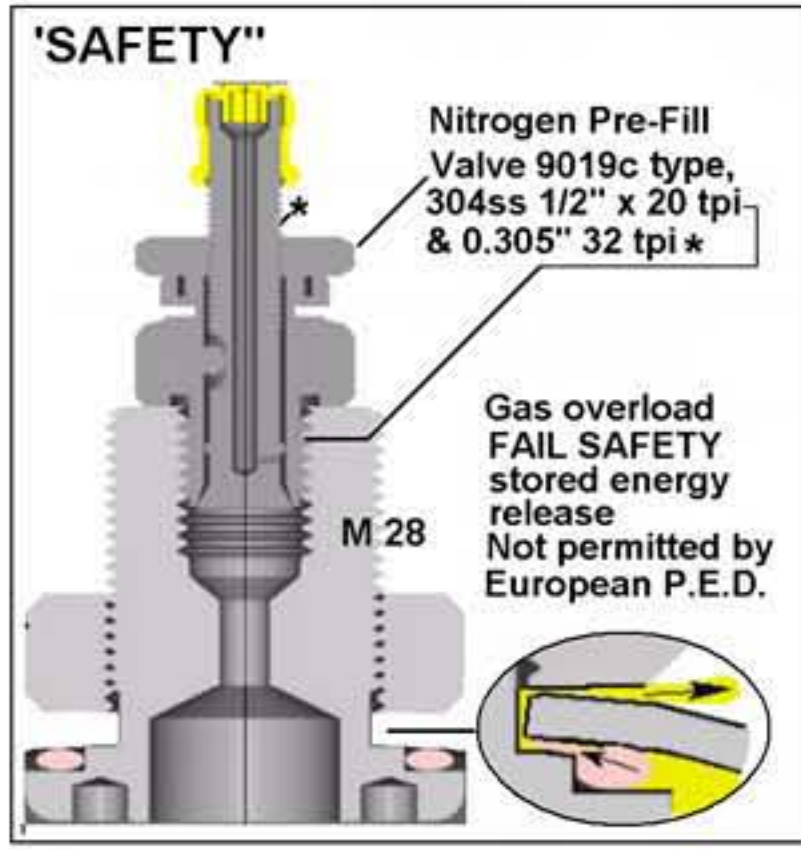
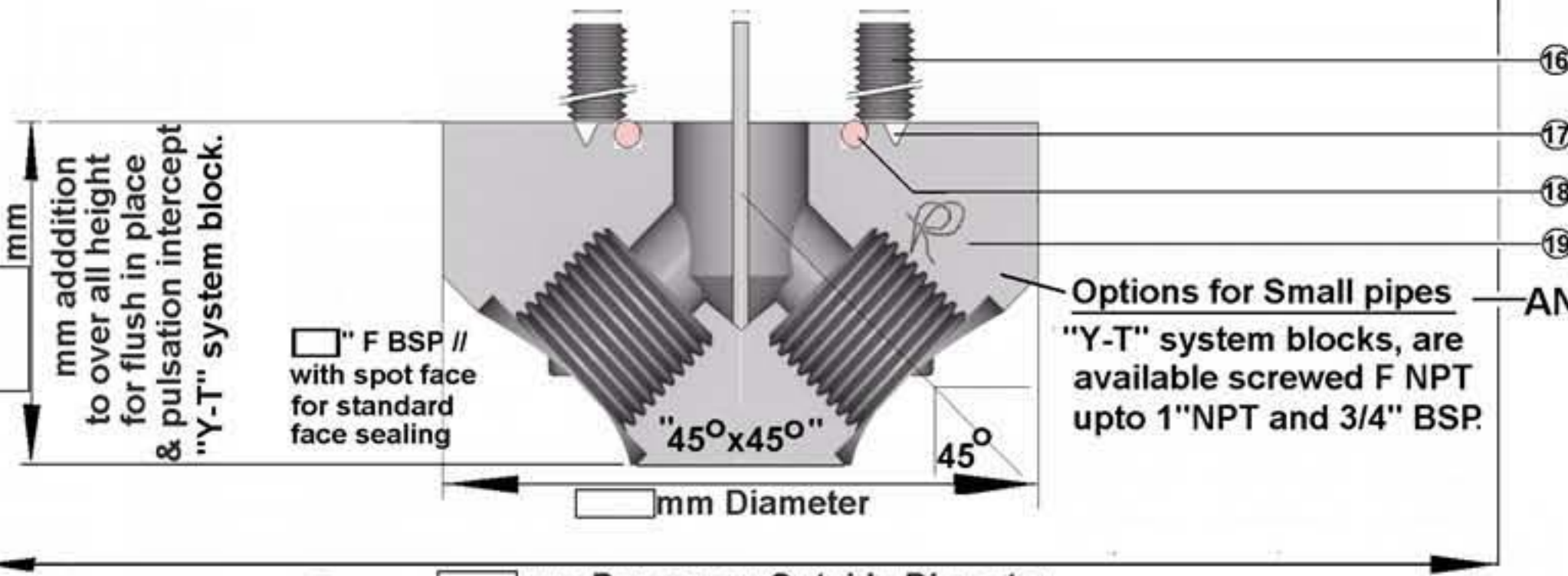
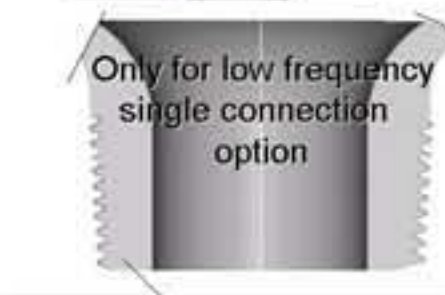
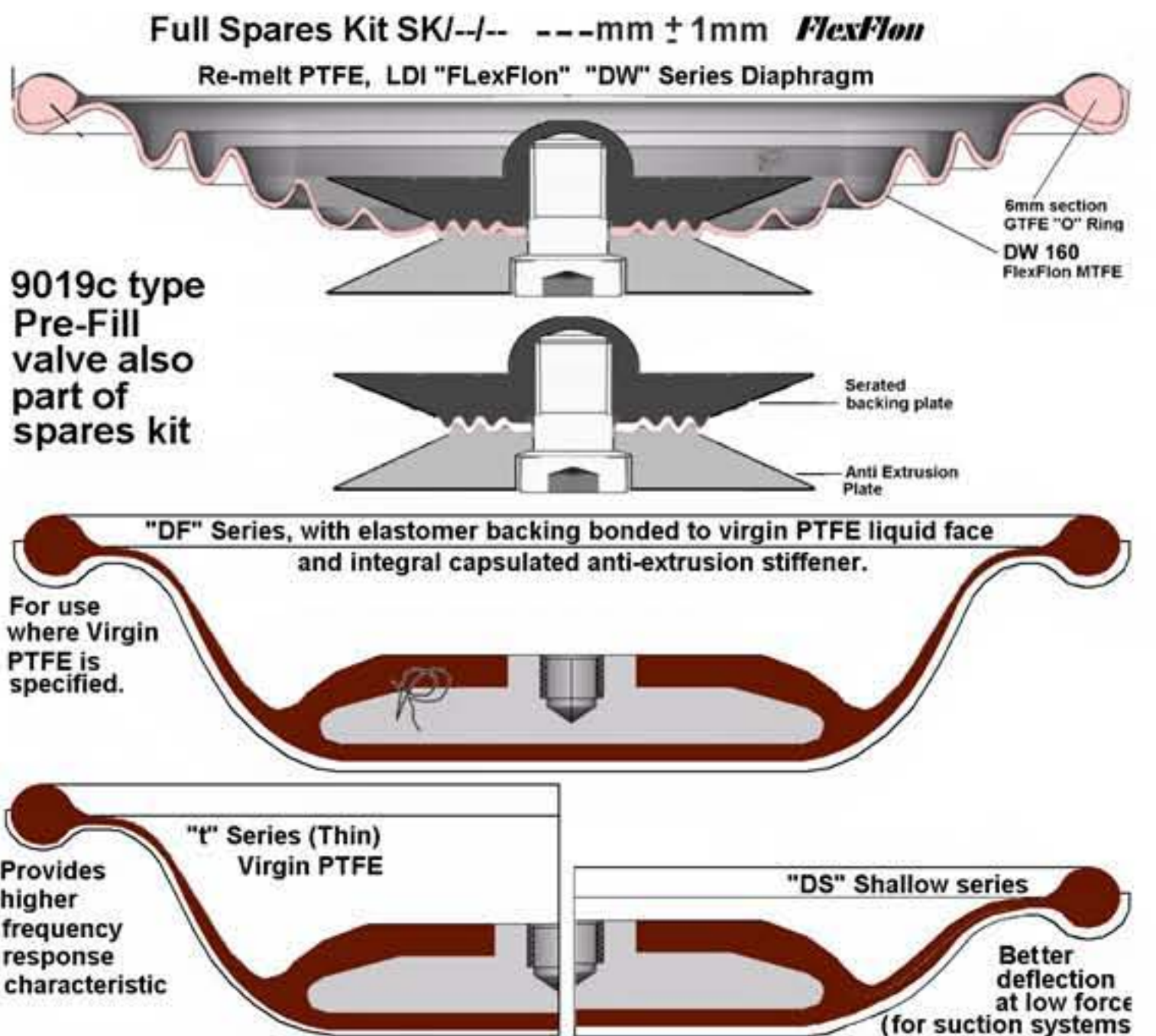

**PulseGuard "Y-T" block, best flanging to system. In place of System "T", better flushing, & intercepts Pressure wave pulsation. For 37.5° butt weld only.**

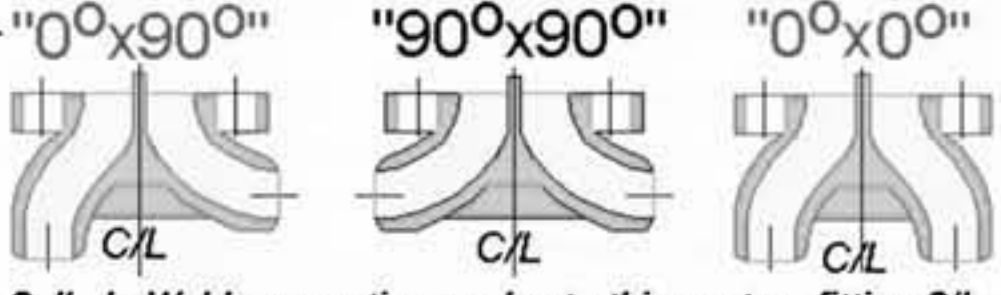

Item Nbr	Description / function	Internal "Heat/Cast No" PURCHASE No
22	Stainless Steel Data Plate.	
21	Stainless Steel split line Safety Band	
19	Piping base block, up to 4 ports.	
18	Face "O" seal	
17	Pressure relief escape groove.	
16	Socket head bolting, 4 equi-spaced	
15	Max connection OD to pass between A-A, 101 mm or 4"	
14	1/2" flat washers - Can be 4 by 1/2" socket head bolts or 2.75" PCD	
13	Nuts for 4 by 1/2" socket heads on 2.625" PCD	
12	1" Schedule 160 pipe nozzle, Max ANSI flange 1/2" 600#, 3.75" OD or 3/4" 150# 3.875" OD	
11	Flared transition, 1" sch 160 to 4mm head, hole reinforcement	
10	3 places - All-thread on same Pitch Circle Diameter as boltings	
9	Nuts, 1 for each bolt, 3 per all-thread, provides 1 for mounting	
8	Support ring - liquid side, Contact outside the bolt circle.	
7	Flanged dishing, liquid side, Contact outside bolt circle.	
6	Spacer ring, Contact outside bolt circle.	
5	Flange of dishing, contact outside bolt circle	
4	Support ring - gas side, steel	
3	Large, flat washers.	
2	Bolts 9 places. Mounting, long "all-thread" 3 places.	
1a	N2 Side, Hydro-forged head w/ 28mm aperture	
1	Nitrogen Side, Hydro-forged head w/Prefill boss	

Scale : Please do not print without "MAINTAIN ASPECT RATIO" on, Use A3 paper  
Part Nbr. / Drawing Ref : \_\_\_\_\_ Date \_\_\_\_\_ th 200- Rev Nbr 1.  
SoG/ssl / l / p / DW "O" / 316L-PTFE + PB "x" / M NPT 316L

**PulseGuard** <http://www.PulseGuard.com>  
**PulseGuard für Deutschland** <http://www.PulseGuard.co.uk>  
**PulseGuard, de langue Francaise** [www.pulsationdaempfer.com](http://www.pulsationdaempfer.com)  
**PulseGuard, en Espanol / sud Amerique** [amortiguador-de-pulsaciones.com](http://www.amortiguador-de-pulsaciones.com)  
**PulseGuard, diya Russkogovoryaschih** [pulsations-dampfer.com](http://www.pulsations-dampfer.com)

PulseGuard is the USA registered trade mark of PulseGuard Inc.  
 PulseGuard is the UK registered trade mark of PulseGuard Ltd.  
 UK --44(0)161-480-9625 USA ---1910-270-2737